

Department of Engineering
Tim Bryan, P.E., County Engineer

3137 South Liberty Street, Canton, MS 39046
Office (601) 790-2525 FAX (601) 859-3430

MEMORANDUM

June 29, 2022

To: Sheila Jones, Supervisor, District I
Trey Baxter, Supervisor, District II
Gerald Steen, Supervisor, District III
Karl Banks, Supervisor, District IV
Paul Griffin, Supervisor, District V

From: Tim Bryan, P.E.
County Engineer

Re: Petition for Traffic Calming
Trace Harbor Drive
Supervisor District 1

The Engineering Department received a petition from citizens for traffic calming along Trace Harbor Drive. They have completed steps 1-3.2 of the Madison County *Policy on Traffic Calming*.

It is the recommendation of the Engineering Department to install speed humps along Trace Harbor Drive as shown on the attached plan which was designed by the County Engineer and included with the final petition for signatures.

SHEILA JONES
District One

TREY BAXTER
District Two

GERALD STEEN
District Three

KARL BANKS
District Four

PAUL GRIFFIN
District Five

PETITION TO INSTALL SPEED HUMPS ON TRACE HARBOR DRIVE

Before you sign this petition, know what you are signing!

We, the undersigned residents of the area shown on the attached Layout Plan (totalling 4 sheets), petition the Madison County Board of Supervisors to install speed humps on Trace Harbor Drive. As required by County Policy, all persons signing this petition acknowledge and hereby certify that they own a home or reside within the area to be impacted by the speed humps. All persons signing also acknowledge and certify that they have read the attached advantages and disadvantages of speed humps.

Address	Homeowner as Listed on Tax Assessors Site	Tenant (If applicable)	Phone Number	Signature
Summit Drive				
1	100	Dale & Nina Lofton		<i>[Signature]</i>
2	101	Luke & Anne-Marie Langlois		
3			Ethan Zeigler	
Trace Harbor Drive				
4	100	Groves TB ET UX		<i>[Signature]</i>
5	101	Heidleburg Properties Vacant		
6			Pattie Sixin	
7	102	Trent Bland	601 941 9631	
8	103	Grady Howell	601 856 7062	<i>[Signature]</i>
9	104	Melanie Whittington	601 940-1626	<i>[Signature]</i>
10	201	Tiffany Ledbetter	727 515 8594	<i>[Signature]</i>
11		2	Joseph Conner ^{corrected}	601 727-515-8274
12	202	Perri Cannady	601 573 8042	<i>[Signature]</i>
13				

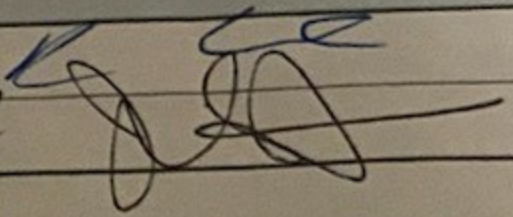
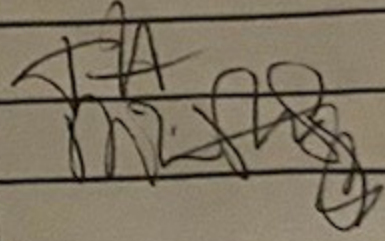
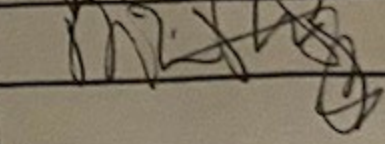
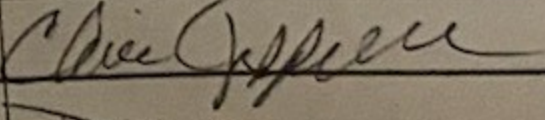
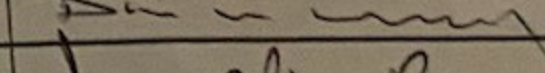
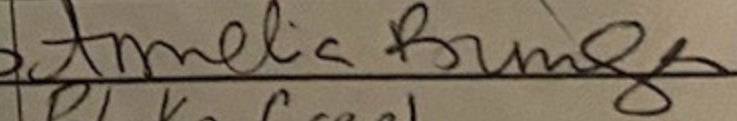
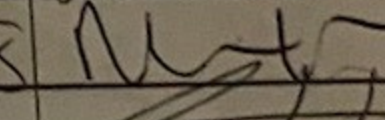
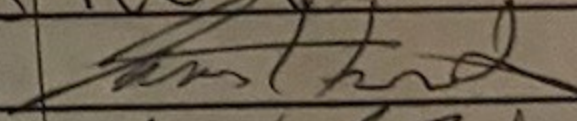
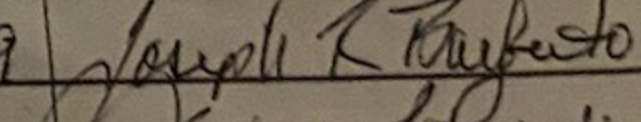
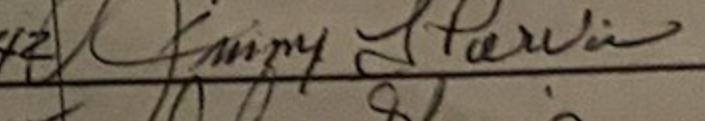
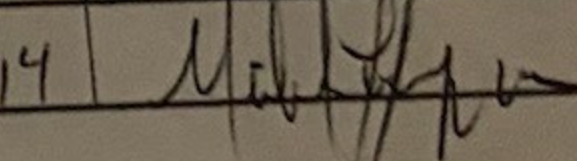
Address		Homeowner as Listed on Tax Assessors Site	Tenant (if applicable)	Phone Number	Signature
Trace Harbor Drive					
14	203	Bradley Hilderbrand		6625711753	
15			Vacant Tiffany Ledbetter	727-612-6482	
16	204	Philip Simon	Vacant		
17	205	Thomas Hurdle		601-573-9787	
18	206	Michael Montgomery		566 7894	
19	207	Cherie Greenwood			
20			Cherrie Jefferson	601-918-4494	
21	208	Daniel Mc Nervey		601-506-4519	
22	209	Michael & Amelia Bunger		601-624-9513	
23	210	Mathew & Gretchen McCalop	Blake Creel	601-573-3006	Blake Creel
24		no longer owns ↑	Samantha Boone	601-573-3006	Samantha Boone
25	211	Melissa McGuffee		601-200-2018	
26	212	James & Sheryl Hand		601-896-7016	
27	213	Joseph Barbuto		601-856-4079	
28	214	Jimmy & Gloria Purvis		601-856-6742	
29	215	Vanessa and John Arthur Pickler	John Shaw	601-573-2645	John Shaw
30					
31	216	Deborah Broadfoot		601-513-9229	Deborah Broadfoot
32	217	Michael & Terry Layman		601-906-9414	

~

Address		Homeowner as Listed on Tax Assessors Site	Tenant (if applicable)	Phone Number	Signature
Trace Harbor Drive					
33	218	Deborah Broadfoot		601-573-9299	DBroadfoot
34	219	Kerry Don Lee Et Ux Tammala W R		601 519 8425	Kerry Don Lee
35	220	Robert & Martha Jackson		601 898 9991	Robert Jackson
36	221	John Andrew & Leah West		601-896-7216	John West
37	222	James McNeer		601-842-8732	James McNeer
38	223	Michael Scott Minton			
39			John Snowdy	601-672-1106	John Snowdy
40	224	Jaqueline Duckworth Jackie Alexander	Jackie Alexander	601 940 3744	Jackie Alexander
41			Daniel Cole	769-231-2701	Daniel Cole
42	225	Thomas Holder		601-856-2852	Thomas Holder
43	226	Ola & William Prince		601 331 4103	William Prince
44	227	Billy Mithcell Bennett		769-216-8379	Billy Bennett
45	228	Kennith Gardner		601-927-3339	Kennith Gardner
46	229 X	Michael & Janet West X			
47	230	William & Michelle Cannady		601-278-8831	William Cannady
48	231	Jaqueline Duckworth Jackie Alexander	Rebekah Reagen Josh Ingram	601 940 3744	Jackie Alexander
49	232	Anthony White	Melody White	601-621-9989	Anthony B White
50	233	Connie Bennett Miller		601-946-0593	Connie Miller
51	234	Jerry Sciple		601 624 3637	Jerry Sciple

Trace Harbor Drive		Lot's Site	Owner Name (if applicable)	Phone Number	Signature
52	235	Willis Harden & Cierra Rhymes			
53					
54	236	Gerald & Phyllis Conrad			
55	238	Gerald & Phyllis Conrad			
56	240	Karen Jean Dierolf			
57	301	James & Heather Love			
58	302	William Thomas		601-927-8557	Heather Love
59				Heather Thomas 601507	
60	303	Christpoher & Dana Thornton		601-927-2350	Christpoher Thornton
61					
62	304	Regina & Joel Wall			Regina Wall
63	305	William & Peggy Clark			
64	306	Timothy Ford Bradley Hildebrand			
65			Sarah Stephens	Sarah Stevens	4073074544
66	307	Joelyn Hennessy		Joelyn Hennessy	601-850-3060
67	308	James Sappington		James Sappington	601-308-0779
68	309	Chace & Jessica Cummins		Chace Cummins	601-23-7030
69	310	Patrick McCoy		Patrick McCoy	601 454 3935
70	311	Nicholas & Katherine Turner		Houston Maegan McDavitt	662-312-6223

Address		Homeowner as Listed on Tax Assessors Site	Tenant (if applicable)	Phone Number	Signature
Trace Harbor Drive					
71	312	Thomas Scoggins		601-978-6311	<i>[Signature]</i>
72	313	Kite Properties LLC	Anthony Regard		<i>[Signature]</i>
73	314	Perry & Fatissa Allen		601-832-7009	<i>[Signature]</i>
74	315	Andrea Riley		601-906-6515	Andrea Riley
75			Curtis Greenwood	601-906-6515	Curtis Greenwood
76	316	Casey Rippy		601-506-9619	<i>[Signature]</i>
77	317	Michael Willoughby		601-668-313	<i>[Signature]</i>
78	318	Joseph & Jessica Pradillo		360-742-4317	<i>[Signature]</i>
79	319	Michael & Betty Willoughby		601-668-313	<i>[Signature]</i>
80	320	Richi Lesley			
81			David Owens	310-975-9300	<i>[Signature]</i>
82	322	Zaking Hawkins		601-951-4818	<i>[Signature]</i>
83	323	Tyler & Amanda Johnson			
84		Melissa Bradley		601-479-5601	Melissa Bradley
85	324	Katherin & Patrick Lett		601-548-6670	<i>[Signature]</i>
86	325	Ricky Griffis			
87	326	Roger & Mona Shedd		601-383-2203	<i>[Signature]</i>
88	327	Shauna Godfrey	Shauna Godfrey	601-862-8141	Shauna Godfrey
89	328	Nicholas & Marisol Cruz			

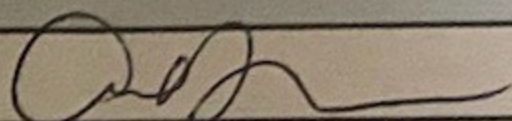
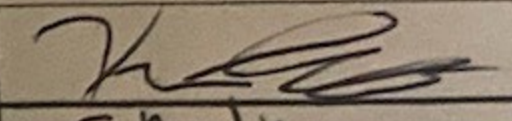
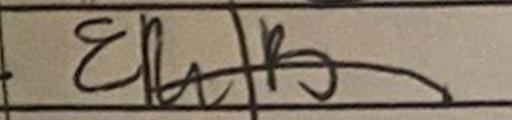
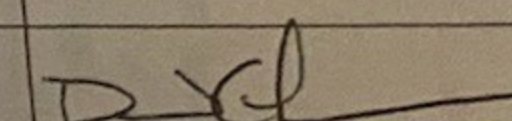
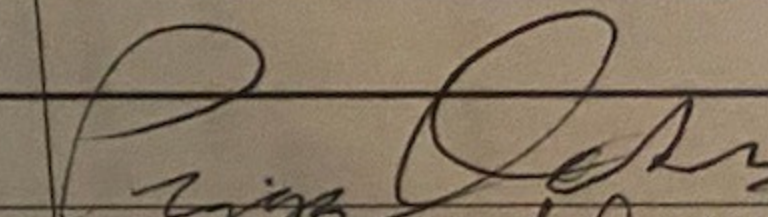
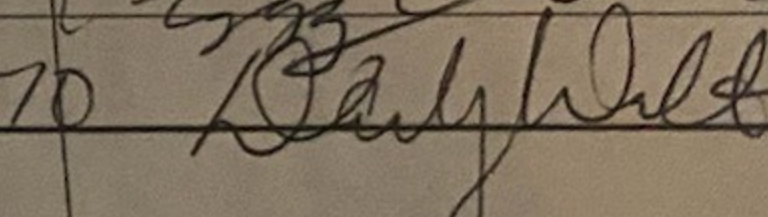
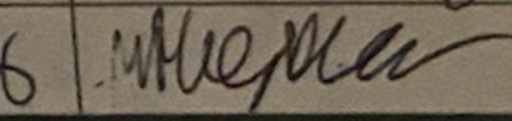
Address		Homeowner as Listed on Tax Assessors Site	Tenant (If applicable)	Phone Number	Signature
Trace Harbor Drive					
90	329	Amanda Bowers		601-9064537	
91	330	Nicholas Wooten no longer owns			
92			Keaton Treadwell	601-500-0097	
93	331	Edwin Burns		601-672-3102	
94	332	Judy White X			
95	333	Ashley Derosia	Married		
96			David Love	601 954 9030	
97	334	James Dixon Williams X			
98	335	Peggy Oakes			
99			Darby Walton	602-711-8570	
100	336	Lela Myers & Jerry Carter			
101			Miles Neltz	731 402 9036	

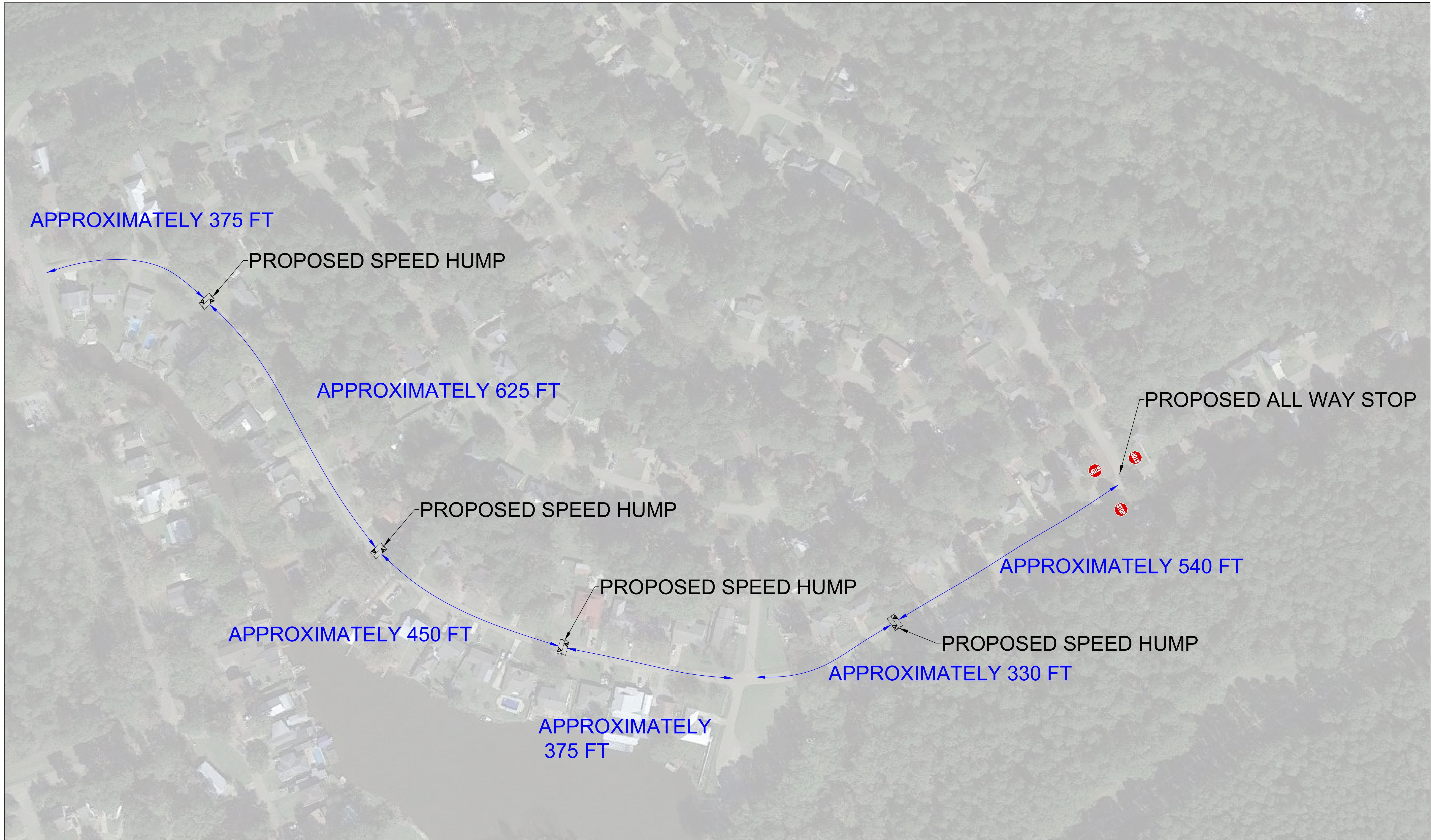

THIS DRAWING REPRESENTS DESIGNS PREPARED BY THE MADISON COUNTY ENGINEERING DEPARTMENT FOR SPECIFIC USE ON THIS PROJECT AND IS NOT TO BE COPIED, REPRODUCED OR ALTERED WITHOUT THE EXPRESS WRITTEN CONSENT OF THE MADISON COUNTY BOARD OF SUPERVISORS REPRESENTATIVE AUTHORIZED TO APPROVE THIS USE. UNAUTHORIZED USE IS SUBJECT TO LEGAL ACTION UNDER STATE AND FEDERAL LAW.

**FOR NEIGHBORHOOD
REVIEW ONLY**

REVISION NO.	DESCRIPTION	DATE	BY:



**MADISON COUNTY
BOARD OF SUPERVISORS**
ENGINEERING DEPARTMENT
3137 SOUTH LIBERTY STREET
CANTON, MISSISSIPPI 39046
SCALE: **NTS** PLOT SCALE: DRAWN BY: **TB** CHECKED BY: APPROVED BY: DATE: **4-14-2022**

PROJECT LAYOUT
**SPEED HUMP PLACEMENT
TRACE HARBOR DRIVE**
DRAWING NO. **1** REVISION NO. **0**

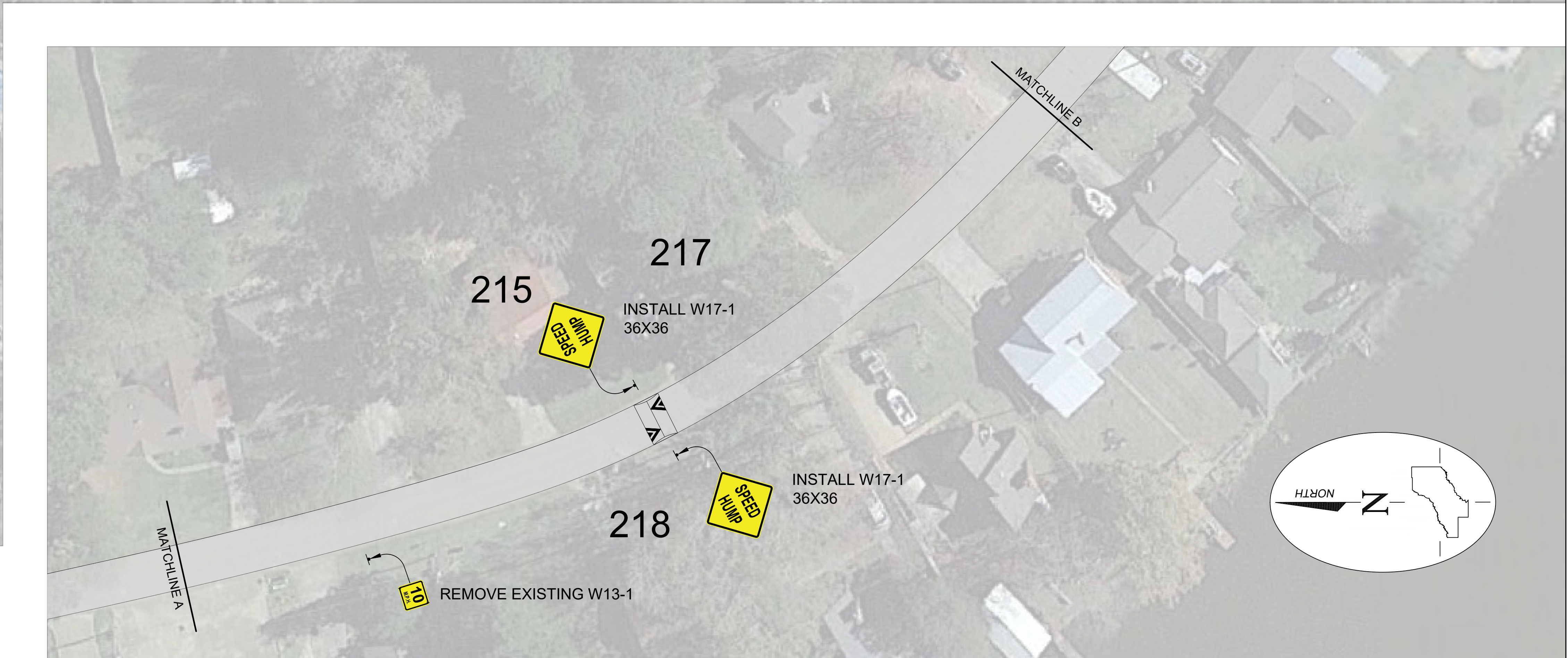

THIS DRAWING REPRESENTS DESIGNS PREPARED BY THE MADISON COUNTY ENGINEERING DEPARTMENT FOR SPECIFIC USE ON THIS PROJECT AND IS NOT TO BE COPIED, REPRODUCED, OR ALTERED WITHOUT THE EXPRESS WRITTEN CONSENT OF THE MADISON COUNTY BOARD OF SUPERVISORS REPRESENTATIVE AUTHORIZED TO APPROVE THIS USE. UNAUTHORIZED USE IS SUBJECT TO LEGAL ACTION UNDER STATE AND FEDERAL LAW.

FOR NEIGHBORHOOD REVIEW ONLY

REVISION NO.	DESCRIPTION	DATE	BY:



MADISON COUNTY BOARD OF SUPERVISORS
ENGINEERING DEPARTMENT
 3137 SOUTH LIBERTY STREET CANTON, MISSISSIPPI 39046 TEL: (601) 790-2520
 SCALE: 1:30 PLOT SCALE: DRAWN BY: TB CHECKED BY: APPROVED BY: DATE: 4-14-2022

PROJECT LAYOUT
SPEED HUMP PLACEMENT TRACE HARBOR DRIVE
 DRAWING NO. 2 REVISION NO. 0



THIS DRAWING REPRESENTS DESIGNS PREPARED BY THE MADISON COUNTY ENGINEERING DEPARTMENT FOR SPECIFIC USE ON THIS PROJECT AND IS NOT TO BE COPIED, REPRODUCED, OR ALTERED WITHOUT THE EXPRESS WRITTEN CONSENT OF THE MADISON COUNTY BOARD OF SUPERVISORS REPRESENTATIVE AUTHORIZED TO APPROVE THIS USE. UNAUTHORIZED USE IS SUBJECT TO LEGAL ACTION UNDER STATE AND FEDERAL LAW.

**FOR NEIGHBORHOOD
REVIEW ONLY**

REVISION NO.	DESCRIPTION	DATE	BY:



**MADISON COUNTY
BOARD OF SUPERVISORS**

ENGINEERING DEPARTMENT

3137 SOUTH LIBERTY STREET
CANTON, MISSISSIPPI 39046
TEL: (601) 790-2520

SCALE: 1:30 PLOT SCALE: DRAWN BY: TB CHECKED BY: APPROVED BY: DATE: 4-14-2022

PROJECT LAYOUT

SPEED HUMP PLACEMENT
TRACE HARBOR DRIVE

DRAWING NO. 3 REVISION NO. 0

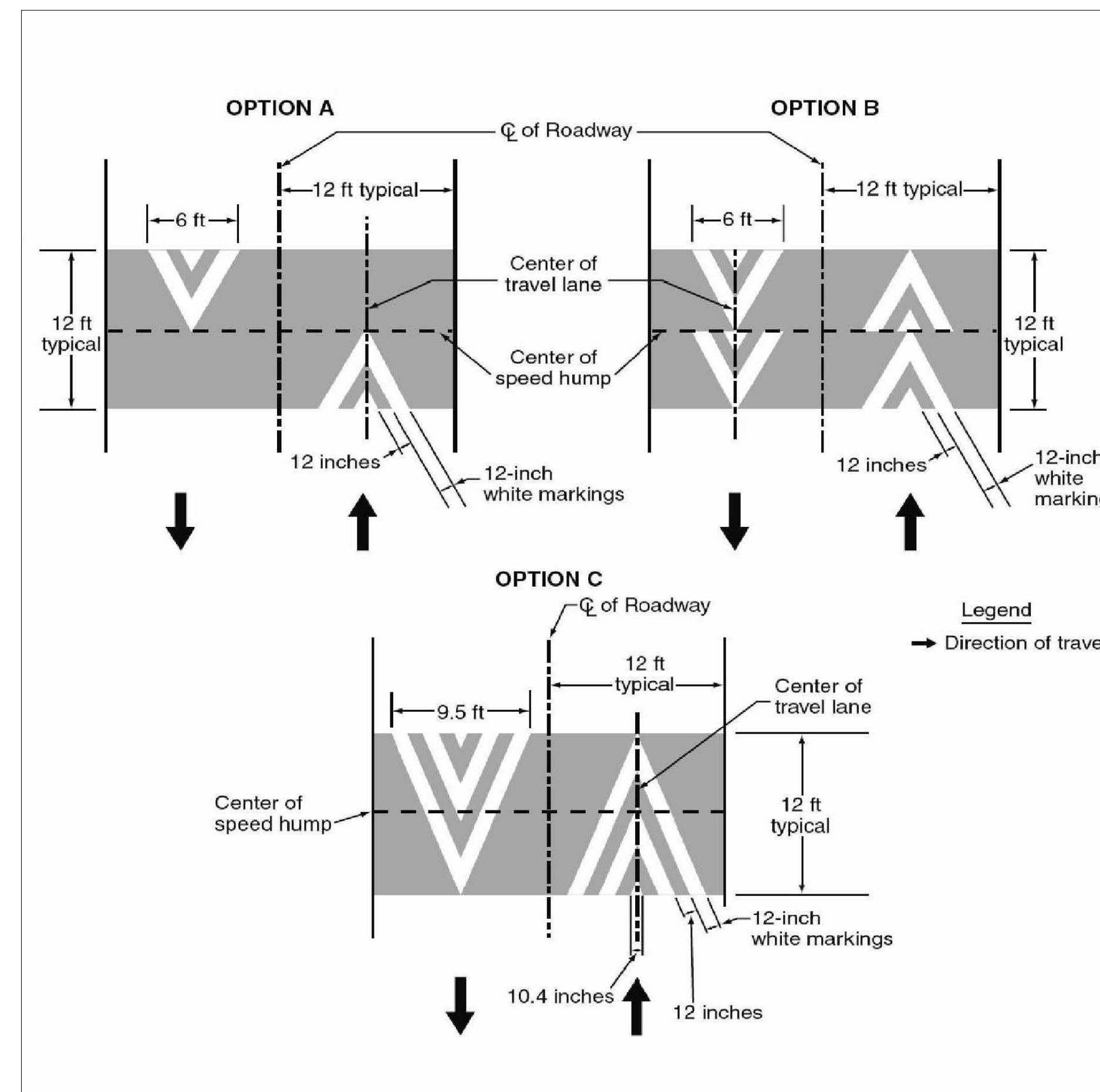
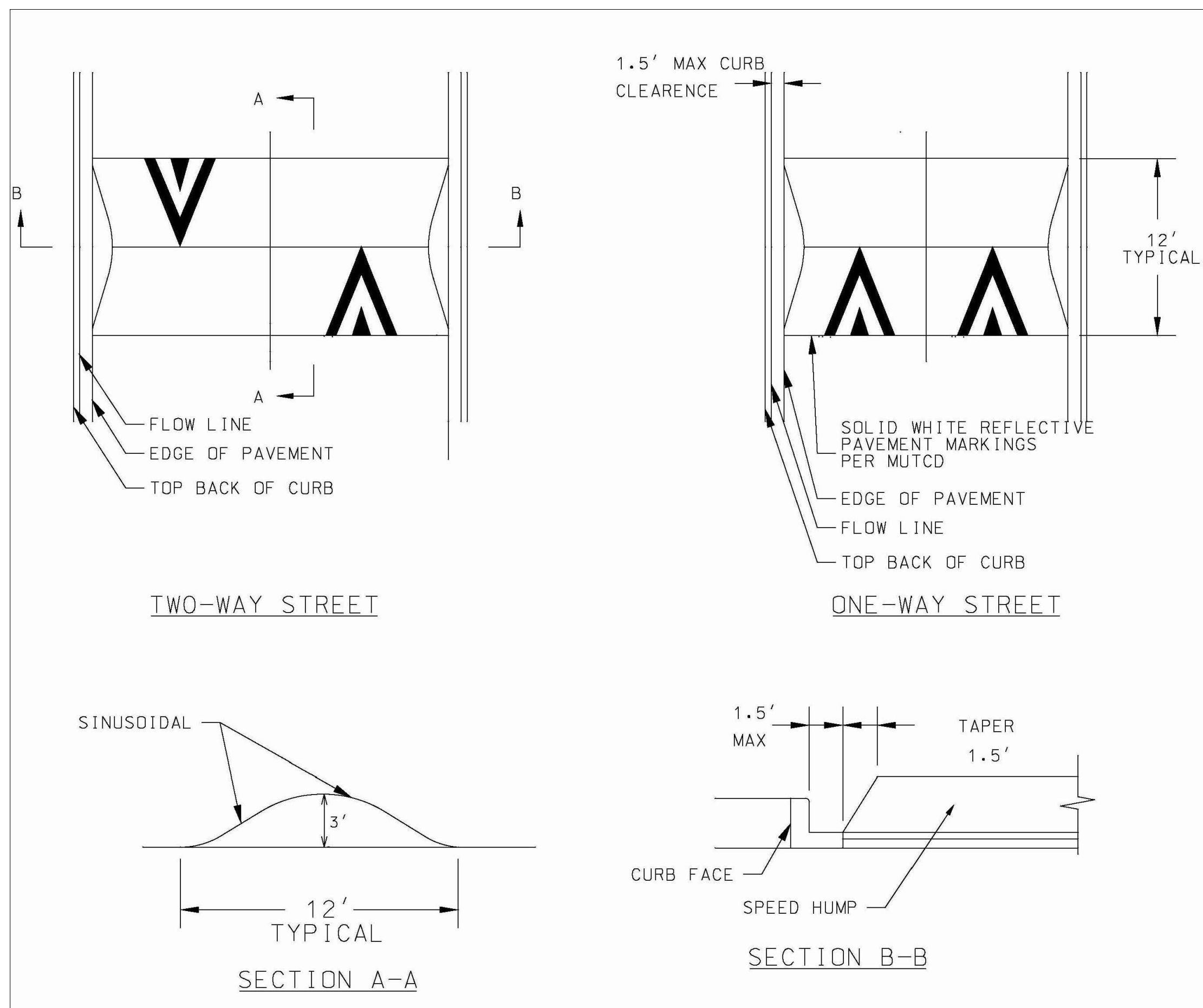

THIS DRAWING REPRESENTS DESIGNS PREPARED BY THE MADISON COUNTY ENGINEERING DEPARTMENT FOR SPECIFIC USE ON THIS PROJECT AND IS NOT TO BE COPIED, REPRODUCED, OR ALTERED WITHOUT THE EXPRESS WRITTEN CONSENT OF THE MADISON COUNTY BOARD OF SUPERVISORS REPRESENTATIVE AUTHORIZED TO APPROVE THIS USE. UNAUTHORIZED USE IS SUBJECT TO LEGAL ACTION UNDER STATE AND FEDERAL LAW.

**FOR NEIGHBORHOOD
REVIEW ONLY**

REVISION NO.	DESCRIPTION	DATE	BY:



**MADISON COUNTY
BOARD OF SUPERVISORS**

ENGINEERING DEPARTMENT

3137 SOUTH LIBERTY STREET CANTON, MISSISSIPPI 39046 TEL: (601) 790-2520

SCALE: 1:30 PLOT SCALE: DRAWN BY: TB CHECKED BY: APPROVED BY: DATE: 4-14-2022

PROJECT LAYOUT

**SPEED HUMP PLACEMENT
TRACE HARBOR DRIVE**

DRAWING NO. 4 REVISION NO. 0

Madison County, Mississippi Board of Supervisors

Policy on Traffic Calming

Introduction:

Traffic Calming has proven to be an effective device in reducing speeds on certain types of roads and streets. Counties nationwide have used traffic calming devices and experience has demonstrated that the devices reduce travel speeds and do not affect the safe operation of motor vehicles. In order to minimize driver frustration and encourage safe driving practices, it is imperative that calming devices be installed in accordance with the transportation engineering criteria stated in this policy. Calming devices will be considered as part of the County's traffic calming activities on minor, residential streets or roads in the unincorporated areas of Madison County.

Eligibility for Traffic Calming Devices:

- Streets or Roads must be classified as "public" on the County's Official Road Registry, and will be minor, residential in nature primarily serving local residents, have minimal truck and transit traffic, and have volume of 2000 vehicles per day or less.
- The road must be paved and have a speed limit of 35 mph or less.
- Streets or Roads that are classified as arterials or collectors or that have more than two travel lanes or 40 feet in width **will not** be eligible for traffic calming.
- Traffic calming devices **will not** be used on streets or roads that fire or emergency service vehicles use as primary routes.
- Traffic calming devices **shall not** be installed on roadways where the County Engineer determines they cannot be safely installed due to severe horizontal or vertical curves, inadequate sight distance to the devices, or have excessive longitudinal grades.

Approval Process:

Step 1:

1. For a roadway identified as the impact area(s) as defined by the County and in order for traffic calming devices to be considered, 51% of the property owners and residents of non-owner occupied properties along the roadway, or who normally use the roadway for ingress and egress to their property, must submit a petition to request a study to evaluate the feasibility of traffic calming device(s) to the Madison County Board of Supervisors. The petition form may be received from the Madison County Engineering office.
2. A letter of support from the Homeowners Association, if applicable, must accompany the petition.

Step 2:

1. A traffic study will be performed by the County Engineer to evaluate the request to determine whether the roadway meets guidelines for a residential area.
2. If devices are warranted, the County Engineer will meet with representatives of those requesting the traffic calming devices to discuss options.
3. If the traffic calming devices are required and agreed upon, the County Engineer will mark the location of the devices for a review by the homeowners.

Step 3:

1. For the defined impact area(s), a final petition of 75% of the property owners and residents of non-owner occupied properties along the roadway, or who normally use the roadway for ingress and egress to their property, must submit a petition to the Madison County Board of Supervisors. The petition form may be received from the Madison County Chancery Clerk's office or County Administrator's office; and
2. The Madison County Board of Supervisors shall make the final determination whether the requested speed hump will be installed based upon the following:
 - a) Recommendation of the County Engineer for placement and location in accordance with safe engineering principles; and
 - b) A petition for the request signed by no less than 75% of the effected property owners as described in this section along with support from Homeowners Association
3. The Madison County Board of Supervisors, in its discretion, may elect to install speed humps or not install speed humps for good cause.

Removal of Speed Humps:

The Madison County Board of Supervisors may consider removing speed humps after they have been in place a minimum of two years and 75% of the effected property owners and Homeowners Association, as described above, sign a petition to have them removed, or some safety or engineering issue adversely impacts traffic on the roadway.

Approved the _____ day of _____, _____.

ADVANTAGES AND DISADVANTAGES OF SPEED HUMPS

Although there are several devices in the “traffic calming toolbox”, speed humps are the devices most often requested.

Advantages:

- Speed humps have been documented to effectively lower speeds when properly installed.
- Residents typically support them and are willing to put up with the negative impacts discussed under “Disadvantages”.
- They can effectively reduce traffic volumes by encouraging drivers to use other routes. Note that this can be seen as a negative impact by those living near the alternate routes.
- Lower speeds may improve pedestrian and bicycle safety.
- Speed humps are relatively inexpensive compared to other physical traffic calming measures such as traffic circles, road narrowing and the creation of mid- block cul-de-sacs.
- They can give the public a sense of involvement and an ability to affect the speeding in their neighborhood.
- Speed humps reduce the need for police enforcement of speed.

Disadvantages:

- Speed humps have a documented negative impact on the response time of emergency vehicles.
- They can cause loose objects to be thrown around in an ambulance, fire truck or other vehicle if crossed at too high of a speed.
- They can be controversial; while many support them, there are residents who dislike them.
- Speed humps cause an increase in noise due to slowing and accelerating vehicles.
- They cause a slight increase in gasoline consumption and emissions.
- They can cause discomfort for people with certain ailments such as back problems.
- They can divert traffic onto neighboring streets, thus transferring a traffic problem to someone else.
- Some of the public will typically find the humps and the associated signs and pavement markings aesthetically unpleasing.

The County Engineer may discuss or recommend other devices.

